



**LMS-D24 / LMS-D26
DIGITAL LOUDSPEAKER
MANAGEMENT SYSTEM**

USER MANUAL

Turbosound Ltd.
Star Road, Partridge Green
West Sussex RH13 8RY England
Tel: +44 (0)1403 711447 Fax: +44 (0)1403 710155
web: www.turbosound.com

Version 1.2

QUICK REFERENCE

(LMS-D26 shown)

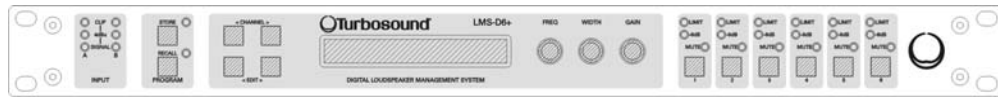

Display

The LCD displays preset and parameter information. At start up the display shows the default screen with the memory location and name of the current preset on the lower line of text.

Channel Select Buttons

The currently selected input or output channel is shown in the top left corner of the display. Pressing the channel select buttons scrolls through the available inputs and outputs. If operating stereo linked the channel name will indicate the channel association. For example 'CH A+B' means both input A and B parameters.

Edit Select Buttons

The name of the edit parameter is displayed in the bottom left portion of the LCD. Pressing the edit select buttons moves through the available parameters for the current input or output.

Parameter Encoders

Up to three parameters are shown on the display. The parameter name is shown with its' current value below. Where appropriate parameters are grouped according to function for example centre frequency, width and gain for parametric EQ. Turn an encoder clockwise to increase the value of a parameter, or anti-clockwise to decrease it. Turning a knob rapidly will cause the action to 'accelerate', so the value changes more rapidly.

Mute Buttons

The LED's next to the mute buttons indicate their current status. Pressing a mute button toggles between the mute on and off.

Store Button

The unit has 45 memory locations and allows users to set up their own programs. To store a preset in a location, press the store button and use the encoders to select the memory location and name the preset. Pressing the store button again completes the task. Pressing any button other than store during the process cancels the procedure.

CONTENTS

Quick reference	2
Display.....	2
Channel Select Buttons.....	2
Edit Select Buttons	2
Parameter Encoders.....	2
Mute Buttons	2
Store Button.....	2
Important Safety Information	5
Regulatory Compliance	5
Thanks	6
Unpacking the controller	6
Introduction	7
Features.....	7
The User Guide	8
Front Panel Functions	9
Rear Panel Functions	11
Operating the LMS series controller	12
Starting up	12
Selecting a Factory Preset	12
Creating a Crossover.....	12
Navigation and Viewing Parameters	13
Navigation.....	14
Presets.....	15
Preset Recall	15
Preset Store	16
DSP Processing Layout	17
Input DSP block diagram	17
Output DSP block diagram	17
Stereo / Mono Formats	17
DSP processing	18
Input Channels.....	18
Parametric Equalisation.....	20
High and Low shelving filters.....	20
Parametric filters	20
Output Channels	21
Gain and Polarity.....	21
Delay.....	21
High and Low Pass Filters	22

user manual
LMS-D24/26

Parametric Equalisation	23
Limiters.....	24
Routing	24
Utilities	25
Utility functions.....	25
Factory Presets	26
EQ and Filter Response Graphs	27
Technical Specifications.....	30
Warranty	31
NOTES	32

IMPORTANT SAFETY INFORMATION

Please read carefully and keep the following instructions and safety information. Heed all warnings and follow all instructions.

- Do not remove covers. There are no user serviceable parts inside, please refer servicing to qualified service personnel.
- This equipment must be earthed.
- Protect the power cord from being walked on or pinched particularly at plugs, convenience receptacles, and the point where they exit from the apparatus.
- Only use attachments/accessories specified by the manufacturer.
- Servicing is required when the apparatus has been damaged in any way, such as the power supply cord or plug is damaged, liquid has been spilled or objects have fallen into the apparatus, the apparatus has been exposed to rain or moisture, does not operate normally, or has been dropped.

Regulatory Compliance

This product complies with both the EMC Directive (89/336/EEC) and the Low Voltage Directive (73/23/EEC) as issued by the Commission of the European Community.

Compliance with these directives imply conformity with the following European standards:

- EN60065 Product safety
- EN55103-1 Electromagnetic Interference (Emission)
- EN55103-2 Electromagnetic Susceptibility (Immunity)

This product is intended for operation in the E2 (commercial & light industrial) and E3 (urban outdoors) Electromagnetic Environments.

Thanks

Thank you for choosing a TURBOSOUND LMS series controller for your application. Please spare a little time to read the contents of this manual, so that you obtain the best possible performance from this unit.

All TURBOSOUND products are carefully engineered for world class performance and reliability.

If you would like further information about this or any other TURBOSOUND product, please contact us.

We look forward to helping you in the near future.

Unpacking the controller

After unpacking the unit please check carefully for damage. If damage is found, please notify the carrier concerned at once. You, the consignee, must instigate any claim. Please retain all packaging in case of future re-shipment.

Introduction

The Turbosound LMS series of loudspeaker management systems represents the current state-of-the-art in digital electronics. The LMS-D24/26 are compact and powerful DSP based audio-processing units designed for use with Turbosound loudspeaker systems and associated bass enclosures, combining the functions of multiple conventional products in a compact 1U high 19" rack unit. To achieve this the LMS-D26 has 2 inputs and 6 outputs (the LMS-D24 features four outputs), which are configured by different factory presets to allow use with a variety of systems. The units are designed to provide specific equalisation and crossover points aimed at optimising the performance of these Turbosound loudspeaker systems. In addition, limiters, delays eq, gain, polarity, and crossover filter controls are accessible to the user in order to match specific operation environments. The LMS series crossovers are designed for quick setup and adjustment via easy-to-use front panel controls.

Features

- Minimal signal path design, providing exceptional audio quality with carefully optimised processing and high performance converters for a full >111dB dynamic range, 96kHz sampling rate and minimal filtering. Audio-grade capacitors are used in the analogue signal path.
- Sonically superb ADC / DAC combination; a carefully matched pairing of the best devices from Burr Brown and Wolfson.
- Newly released family of Analogue Devices SHARC DSP.
- Extended bandwidth; 96kHz sampling frequency provides for a nominally flat response to 40kHz.
- Front panel parameter rotary encoder provides a familiar and easy to use control format with all filter information displayed simultaneously on a backlit LCD display.

THE USER GUIDE

This user manual gives a progressively more detailed description of the functions of the TURBOSOUND LMS-D26 and LMS-D24 loudspeaker management systems. A single page quick reference guide is provided for those users who are experienced with this type of equipment and just need to know how to 'drive' the front panel.

A detailed explanation of the front and rear panel controls and indicators is contained in the next section. The final section describes each individual function or feature with annotated images explaining its use. Where appropriate, the LCD is shown to further elaborate on the unit's operation.

To complete the manual a reference section is included, describing the technical performance of the device complete with graphs of filter responses and details of the *Factory Presets* and their configuration.

Front Panel Functions

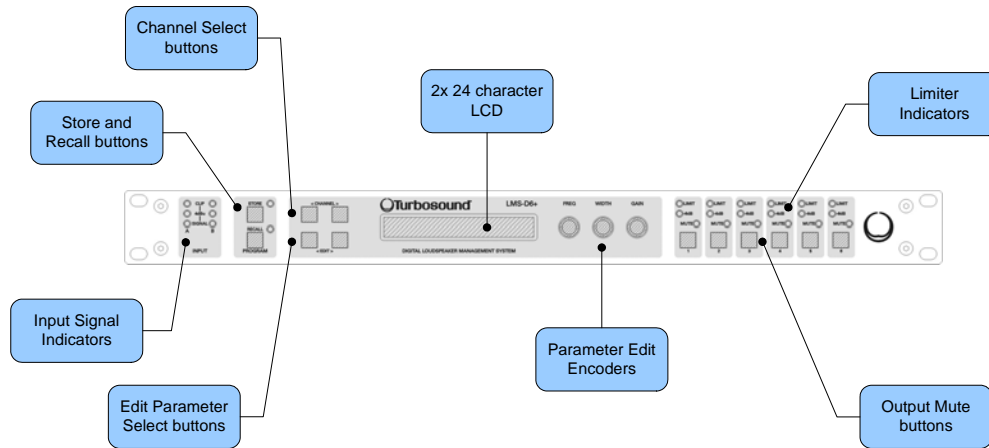

- **Input Signal Indicators** – A set of three pairs of LED's indicate signal present, +4dBu and input clip for both channels. The signal present LED's operate at approximately -40 dBu, giving a useful indication of even relatively low input signal levels. The +4 dBu LED's are intended to show nominal operating level and can also be useful for setting system gain structure. Clip LED's warn the user of input overload and operate at +19 dBu.
- **Program Store and Recall** – these controls provide access to 45 presets. Pressing the store button allows the user to name a preset and choose which memory location it will be held in. Pressing store button again completes the process. The Recall function operates in a similar way, pressing the recall button allows the user to select which preset they require, pressing the button for a second time, then confirming, recalls the new DSP settings. The unit allows the user to set up user programs with full access to all parameters.

Note that presets cannot be stored or recalled when secure mode is activated.

- **Channel Selection Buttons** – the currently selected channel is displayed on the top left hand corner of the LCD. Pressing the channel buttons scrolls through the available input and output channels and finally through the utility functions and back to the default screen. If operating a stereo-linked preset the channel name will indicate the channel pairing. For example 'A+B' means both input A and B parameters. The name of the output will be shown briefly at the top of the display when stepping onto an output.

- **Edit Select Buttons** – the currently selected edit parameter is displayed on the bottom left corner of the LCD. Pressing the edit select buttons moves through the available parameters for the current input or output.
- **Text display** – preset, channel, parameter and status information is shown on the 2x 24-character text display. In most screens the currently selected channel is displayed on the upper line and the edit parameter on the lower line. To simplify the display and enhance security, some parameters or parameter pages are omitted when not relevant.
- **Parameter Knobs** – three velocity sensitive parameter knobs are used to adjust parameters shown on the display. Up to three parameters are displayed on the screen. The parameter name is shown above the parameter value in each of the three screen sections. The parameter knobs have a fixed association with the screen sections; the rightmost parameter knob adjusts the rightmost parameter and so on.
- **Output signal and limiter indication** – two LED's are provided for each output channel. These show the signal level relative to the limiter threshold. The yellow LED will light when the signal is 6dB below the threshold and the red warning LED will light when the limiter threshold is reached.
- **Mute buttons and status LED's** – each output has a mute button and associated mute status LED. Pressing the button toggles the mute on and off.
- *Note that the mute buttons do not function when the Secure Mode is activated.*
- **Secure Button (on the rear)** – a momentary button is fitted behind the rear panel, between the output XLRs and the RS232 port. When activated, this will disable all the front panel controls so they cannot affect the signal path, making the unit secure against tampering. When in secure mode, the indicators still operate normally.

Note that the communications port is still active in secure mode.

Rear Panel Functions

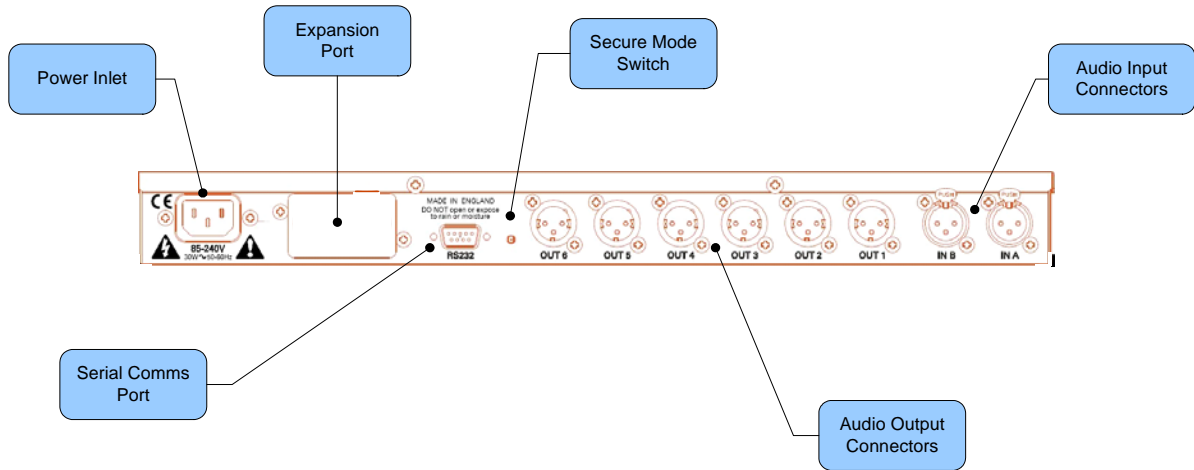

- **Power Inlet** – provides connection to a suitable mains electricity supply using the cable supplied. The controller has a switch mode power supply that is capable of operating with a nominal mains voltage of 80 to 240v, 50/60Hz without re-configuration.
- **Network expansion port** – where a future network card can be fitted.
- **Audio Input connectors** – these are fully balanced and are wired pin 1 ground, pin 2 hot and pin 3 cold. The two inputs have pin 1 connected directly to the chassis and feed the signal processing chains. If an unbalanced source is used, a connection should be made between the pin 3 'cold' signal and the ground connection of the unbalanced source.
- **Audio Output connectors** – the processed outputs are impedance balanced, and are wired pin 1 ground, pin 2 hot and pin 3 cold. An unbalanced input may be driven by by connecting pin 3 'cold' signal to the ground connection of the unbalanced destination input. Note that output pin-1's are ground lifted at audio frequencies but connected to ground at RF for good EMC performance. The intention being that the amplifiers the processor is driving should be responsible for the grounding of their input cable shields.
- **Communications port connector** – the unit may be controlled entirely from another controller (typically a Personal Computer), running an application that is compliant with the ObCom standard. Connection will normally be made to the controller via this serial port connector. This port is also used for updating the firmware in the unit.

Note: The communications port is NOT disabled when the front panel is made secure using the secure button.

OPERATING THE LMS SERIES CONTROLLER

Starting up

The unit will energise as soon as power is applied to the IEC inlet; there is no power switch. During the start up process the firmware application model number and version numbers are displayed and the outputs are muted until the unit has completed its internal checks. Once the start-up routines are complete and the unit is ready to pass audio, the DSP signal path will be restored to the current settings when it was last powered down and the audio signal is gradually ramped up to its correct level.

Selecting a Factory Preset

There is a library of thirty Factory Presets to suit a range of Turbosound enclosures.

Factory Presets contain some parameters that are fixed and hidden from view; the remainder of the DSP parameters are available for user manipulation. The number and type of hidden parameters is dependant on the Factory Preset, typically crossover frequencies, output delay and some EQ's are hidden; those settings that are a function of the loudspeaker cabinet design and should not require adjustment for different applications.

To recall a Factory Preset for a particular cabinet or system, press Recall and use the left hand parameter knob A to scroll through the available factory preset locations (as indicated by a box symbol after the preset number). Once the appropriate preset has been selected press recall again, at which point you will be asked to confirm the action by pressing recall for a third time. This is to guard against accidental recall of Presets.

Factory Presets are locked so they cannot be over-written. The user can, however, store an edited version of a Factory Preset in any free preset location.

Details of all the Factory Presets can be found in Appendix A.

Creating a Crossover

In addition to the *Factory Presets* the unit has two further '*Base Presets*'; mono and stereo. These *Base Presets* are stored in locations 1 and 2 respectively, they can be used to develop settings for any loudspeaker combination and are recalled in the same way as the *Factory Presets* described above. These Presets are also locked but the user can name and store their own edited versions in any free preset location.

Navigation and Viewing Parameters

(Note: The LMS-D26 is shown in all the following screen shots; however the features and parameters apply equally to the LMS-D24)

Many of the processing elements in each input and output path have features that may be controlled by the user, such as gain, frequency or limiter threshold. We call these adjustable features parameters.

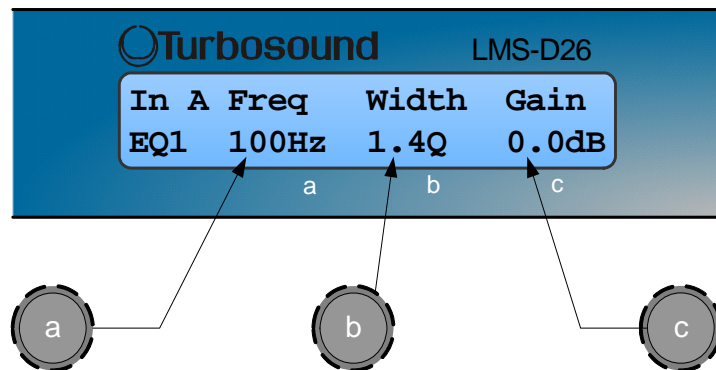

A parameter may be adjusted when it is displayed by turning one of the three-parameter knobs. Each of the three-parameter knobs is associated with a zone on the display. Adjusting the leftmost parameter knob will change the value of the parameter showing in the leftmost zone of the display and so on. Turn a knob clockwise to increase the value of a parameter, or anti-clockwise to decrease it. The knobs are velocity-sensitive so turning a knob rapidly will cause the action to 'accelerate', so the value changes more rapidly.

Navigation

The DSP parameters are organised by channel. The currently selected channel is shown in the top left hand corner of the display. You can navigate between the channels by pressing the channel buttons. Pressing the channel buttons will scroll through the channels, utilities and back to the default screen. When using a Preset that is stereo linked, the channel selection will reflect this. For example '1&4' indicates outputs 1 and 4. When navigating onto an output channel, the usage of the output, as define in the factory preset, will be shown briefly at the top of the screen.

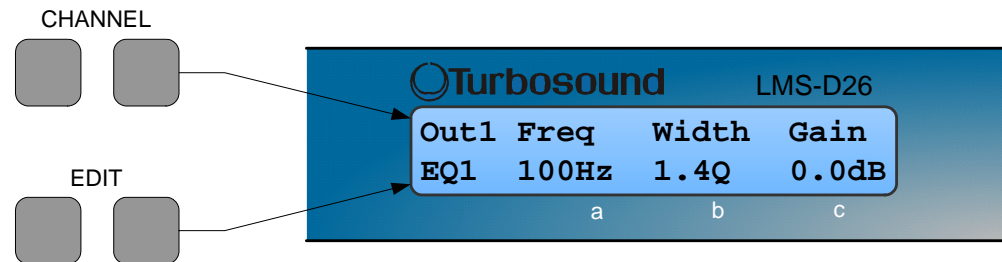

Pressing the edit navigation buttons gives access to the various pages of parameters available for each channel. The currently selected page is shown in the bottom left hand corner of the display, this is omitted on some pages where the function is obvious. The screen shows up to three (normally related) parameters for a given part of the processing functions on a given channel.

The edit buttons allow you to scroll, in either direction, through the different processing pages for a given Channel. When you go past the last page, you will be returned to the default page.

The channel buttons allow you to scroll, in either direction, through the input and output channels, whilst trying to maintain the currently viewed processing block. If the channel you scroll to does not have the currently viewed processing block, the next one will be shown instead.

NB. When the unit powers-up, the settings will be the same as those when the unit was last switched off.

Presets

The device contains a total of forty-five user and *Factory Presets*. The user cannot overwrite the basic mono, basic stereo or *Factory Preset* programs.

Preset Recall

To select an existing Preset, press the Recall Button so the indicator above it illuminates. Turn parameter knob A until the required Preset number is shown on the display. Factory presets are indicated by a box symbol appearing after the preset number. Press the Recall Button again to activate the Preset. Pressing any other button will cancel the operation.

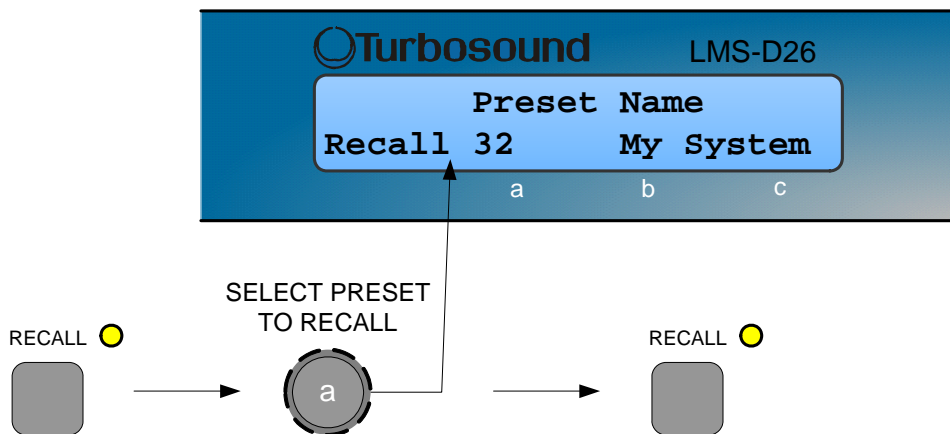

Users can develop their own Preset based on one of the basic or *Factory Presets* stored within the device. Once a basic or user Preset has been recalled, a user has complete freedom to adjust any or all of the parameters. *Factory Presets* can be used as the basis for user Presets but they have some parameters that are predefined as a function of the loudspeaker system. These parameters are 'hidden' from the user, as they should be constant regardless of application.

Preset Store

To store the current Preset in a user location, press the Preset Store Button so the indicator above it illuminates. Turn the first parameter knob until the required Preset location number is show on the display. A Preset name of up to 12 characters in length can be entered using parameter knobs B and C. Pressing the Store Button again completes the process and stores the Preset. As with Preset Recall, pressing any other button cancels the operation.

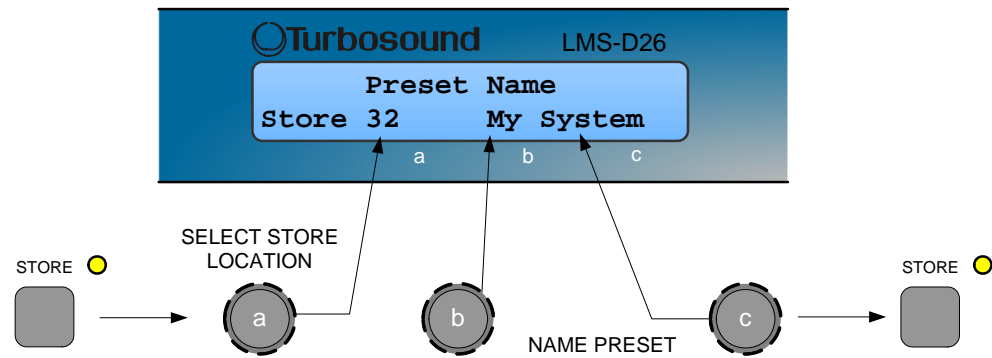

The user can overwrite non-protected Presets only; if an attempt is made to save a Preset in a location already occupied by a basic or *Factory Preset* a 'LOCKED PRESET' message is displayed.

DSP PROCESSING LAYOUT

Input DSP block diagram

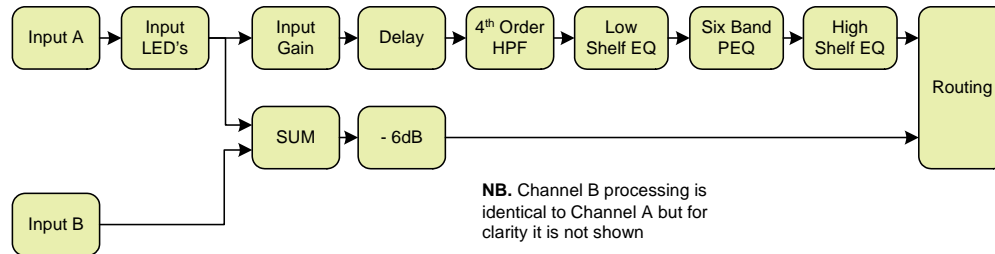

Output DSP block diagram

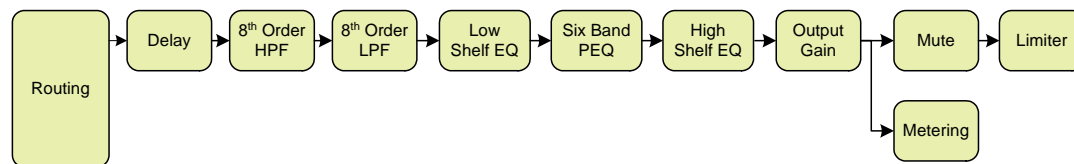

Stereo / Mono Formats

There is only one 'standard' layout of the processing blocks, but flexible routing and control linking allows this layout to be adapted to a wide variety of applications.

There are two 'Formats', Mono or Stereo. With the Mono format, all outputs have unique parameter settings, and all outputs are identical in terms of processing functions and routing capability. This is the most flexible Format.

Stereo format pairs the inputs and outputs for stereo operation, the parameters of each member of the pair being identical. The routing of inputs to outputs is fixed. This format is intended for symmetrical stereo operation, eliminating the need to make identical parameter adjustments for each channel.

The channel pairing is:

- Left and Right Inputs
- Outputs 1 (routed from L input) and 3 (routed from R input) [1 and 4 for LMS-D26]
- Outputs 2 (routed from L input) and 4 (routed from R input) [2 and 5 for LMS-D26]
- [Outputs 3 (routed from L input) and 6 (routed from R input) – LMS-D26 only]

DSP PROCESSING

Input Channels

Gain

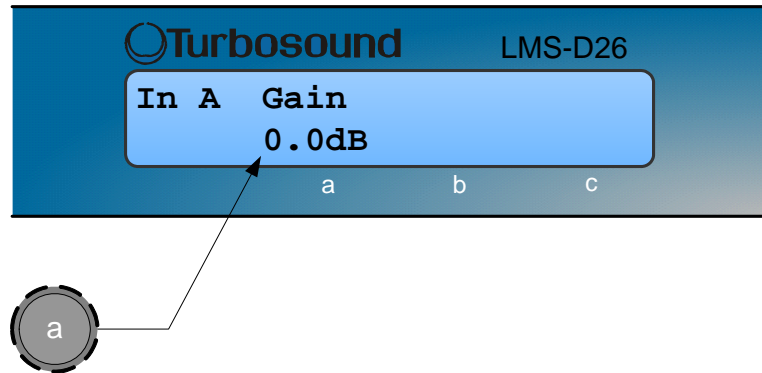

Knob A: Gain, adjustable in 0.2dB steps from -80 dB to +20dB

Delay

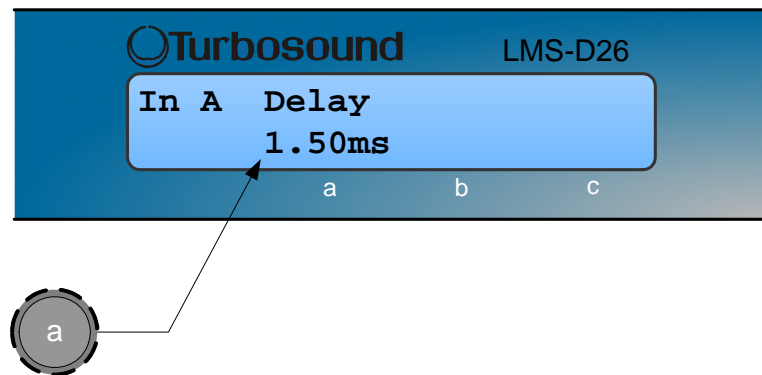

Knob A: Delay, adjustable in variable steps from 0 to 400ms

The delay parameter is adjustable in fine steps at low values; the adjustment becomes progressively coarser as the value increases. The velocity sensitive Parameter Knobs therefore provide accurate setting of driver offset delays (typically below 10ms) and rapid setting of longer system alignment delays.

High Pass Filter

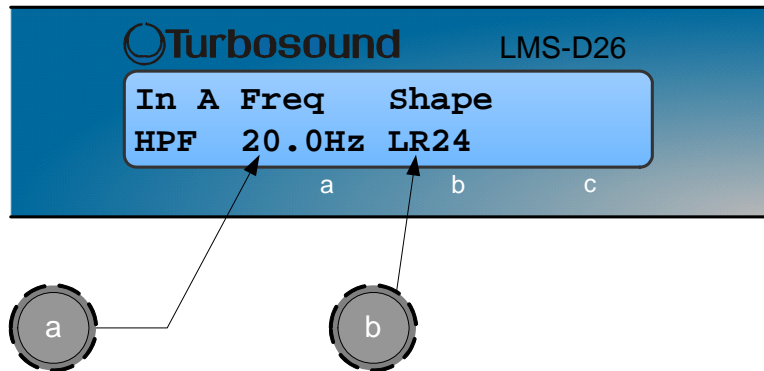

Knob A: Frequency, out (off), 10.0Hz to 25.6kHz in variable steps

Knob B: high pass filter type

System high pass filtering is provided for the input signal. This is the preferred location for high pass filtering as it affects all outputs and can therefore improve inter-band phase relationships. Filter type is selectable from Butterworth, Bessel, Linkwitz-Riley and Hardman. Filter slopes of up to 4th order or 24dB / octave are provided. Not all filter types are available in all slopes. For example 18dB / octave Linkwitz-Riley filters do not exist.

The Hardman type filter is always described by its' order as the filter becomes progressively steeper rather than following a linear slope so a dB/octave description is not accurate.

Parametric Equalisation

Eight sections of equalisation are provided, two shelving filters and six fully variable parametric sections.

High and Low shelving filters

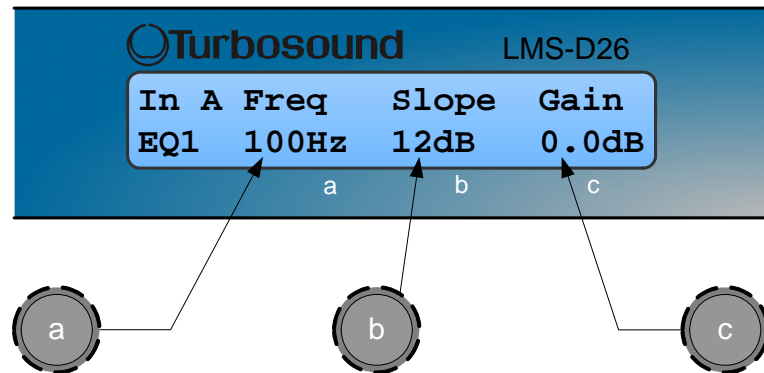

Knob A: Frequency, 10.0Hz to 25.6kHz in variable steps

Knob B: Slope, 6 to 12dB / octave in 1dB steps

Knob C: Gain, +/-15dB in 0.2dB steps

The frequency is specified as point where the filter deviates by 3dB from the gain value.

Parametric filters

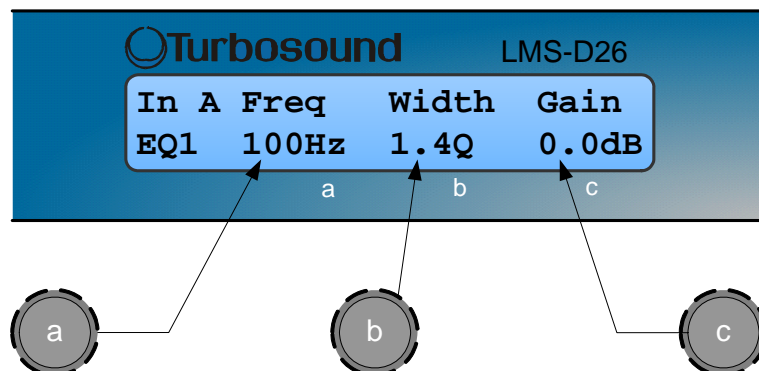

Knob A, Centre Frequency, 10.0Hz to 25.6kHz in variable steps

Knob B, Width, display selectable, Q or BW (Bandwidth)

BW adjustable from 0.05 to 5 octaves in variable steps

Q adjustable from 14.2 to 0.2 in variable steps

Knob C, Gain, +/-15dB in 0.2dB steps

OUTPUT CHANNELS

Gain and Polarity

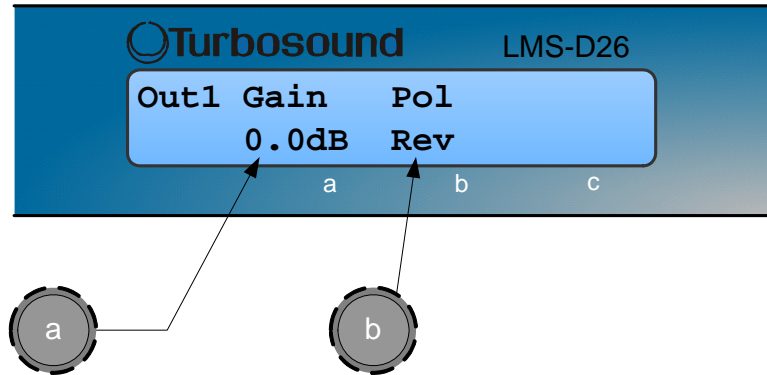

Knob A: Gain, adjustable in 0.2dB steps from -80 dB to +20dB

Knob B: Polarity, selectable, normal or reversed with reference to other outputs

Delay

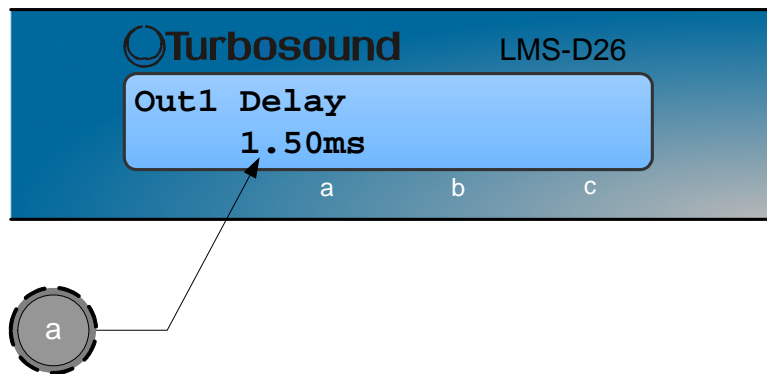

Knob A: Adjustable in variable steps from 0 to 80ms

As for input delay, velocity sensitive Parameter Knobs provide finer adjustment at low levels and rapid selection of higher values.

High and Low Pass Filters

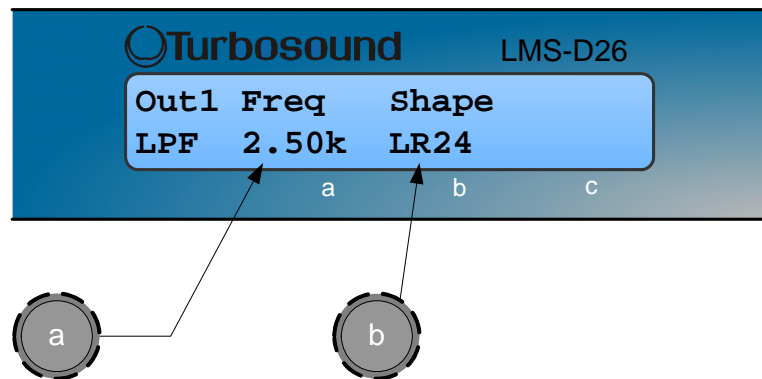

Knob A: Frequency, <<out, 10.0Hz to 25.6kHz, out>>

Knob B: high pass filter type

Filter type is selectable from Butterworth, Bessel, Linkwitz-Riley and Hardman. Filter slopes of up to 8th order or 48dB / octave are provided. Not all filter types are available in all slopes. For example 18dB / octave Linkwitz-Riley filters do not exist.

The Hardman type filter is always described by its' order as the filter becomes progressively steeper rather than following a linear slope so a dB/octave description is not accurate.

Parametric Equalisation

Eight sections of equalisation are provided in a similar format to the input channel equalisation; two shelving filters and six parametric.

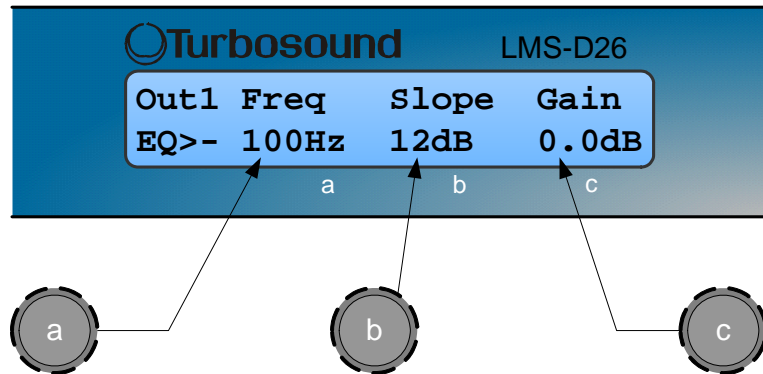

Knob A: Frequency, 10.0Hz to 25.6kHz in variable steps

Knob B: Slope, 6 to 12dB / octave in 1dB steps

Knob C: Gain, +/-15dB in 0.2dB steps

The frequency is specified as point where the filter deviates by 3dB from the gain value.

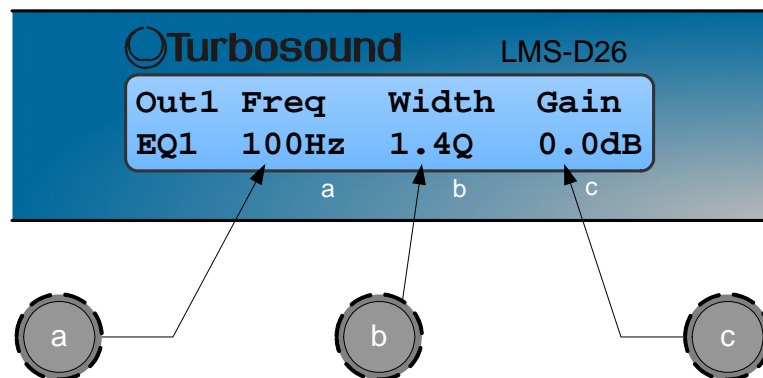

Knob A, Centre Frequency, 10.0Hz to 25.6kHz in variable steps

Knob B, Width, display selectable, Q or BW (Bandwidth)

BW adjustable from 0.05 to 5 octaves in variable steps

Q adjustable from 14.2 to 0.2 in variable steps
Knob C, Gain, +/-15dB in 0.2dB steps

Limiters

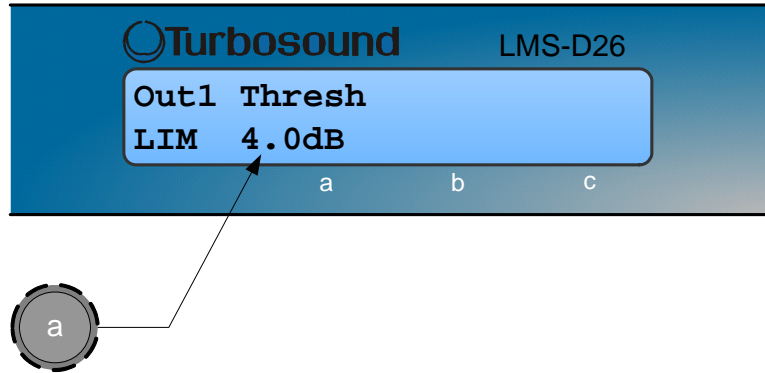

Knob A: Threshold, -40dBu to 20dBu in 0.2dB steps

A high performance, low distortion limiter is provided on each output. Threshold is user adjustable; all other parameters are carefully calculated dependant on configuration to provide clean and effective control of signal dynamics.

Routing

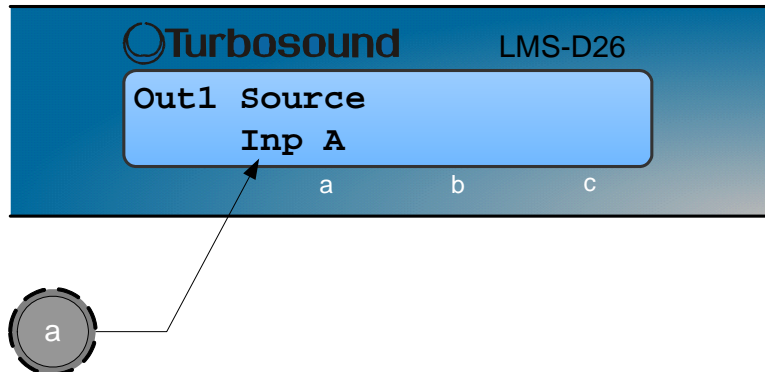

Knob A: Output source, selectable; Input A, Input B or Sum A+B

Configures the routing from input to output. This function is only available in mono format Presets.

UTILITIES

Utility functions

Two utility functions are provided to adjust screen contrast and the display units used for parametric equalisation bandwidth.

The device automatically adjusts for the variations in display contrast as the temperature of the LCD changes. The screen contrast utility control sets the base contrast of the screen and also allows optimization for a given viewing angle.

Parametric equalisation width parameters can be displayed in either 'Q' or bandwidth, expressed in octaves.

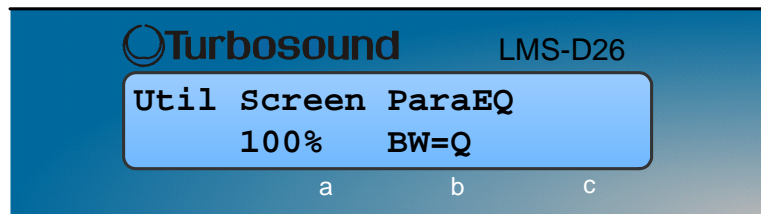

user manual
LMS-D24/26

FACTORY PRESETS

For current factory preset files please visit our ftp site at ftp://ftp.turbosound.com/tech_data/presets/

These files can be loaded via TurboDrive into your controller, or opened in TurboDrive and viewed offline.

EQ AND FILTER RESPONSE GRAPHS

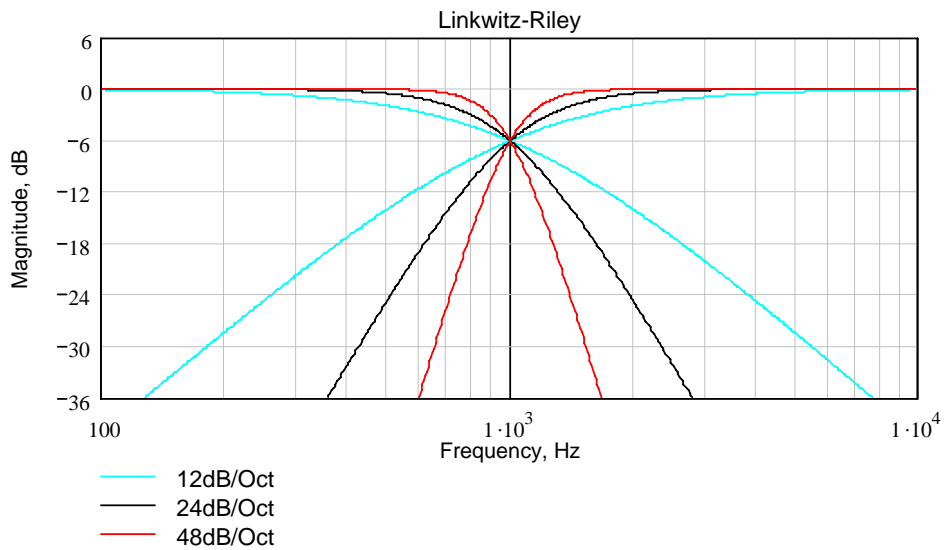
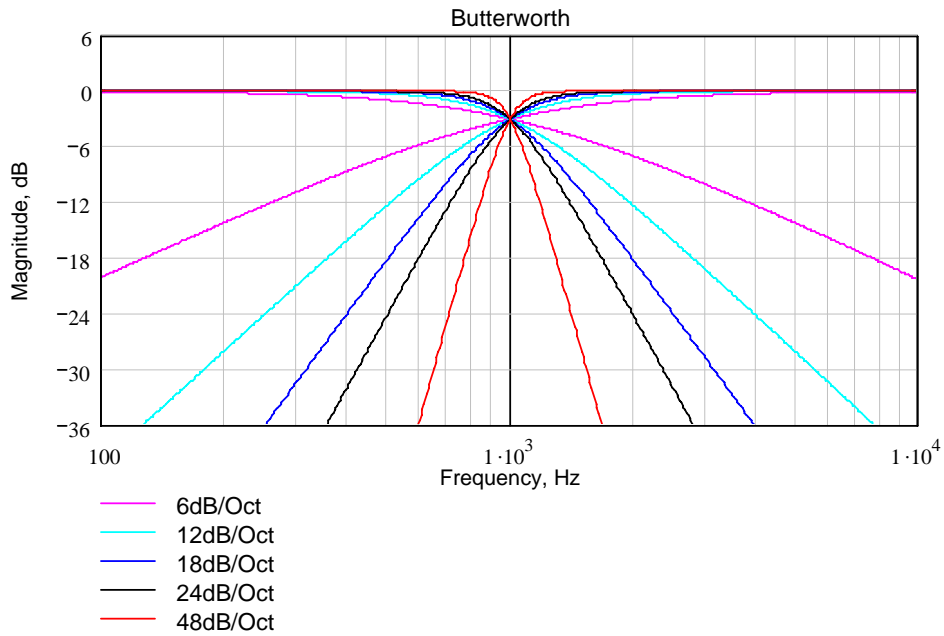

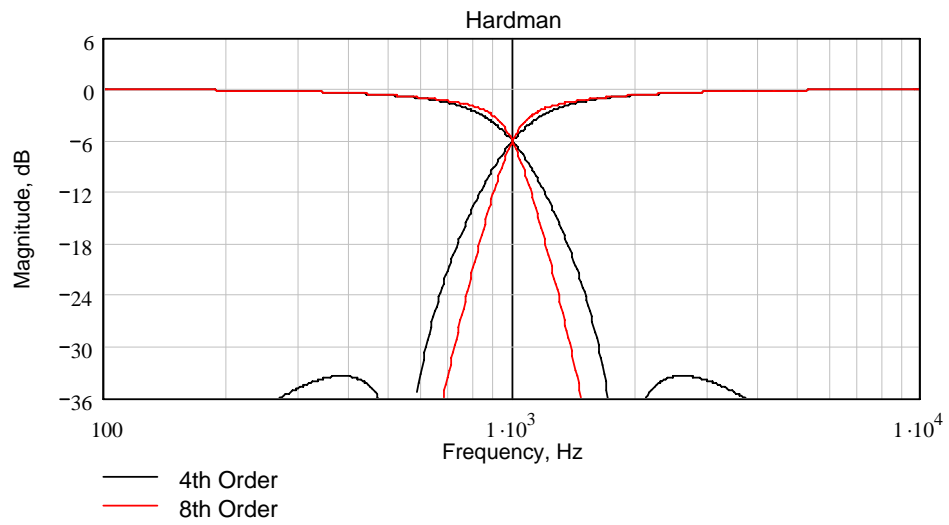
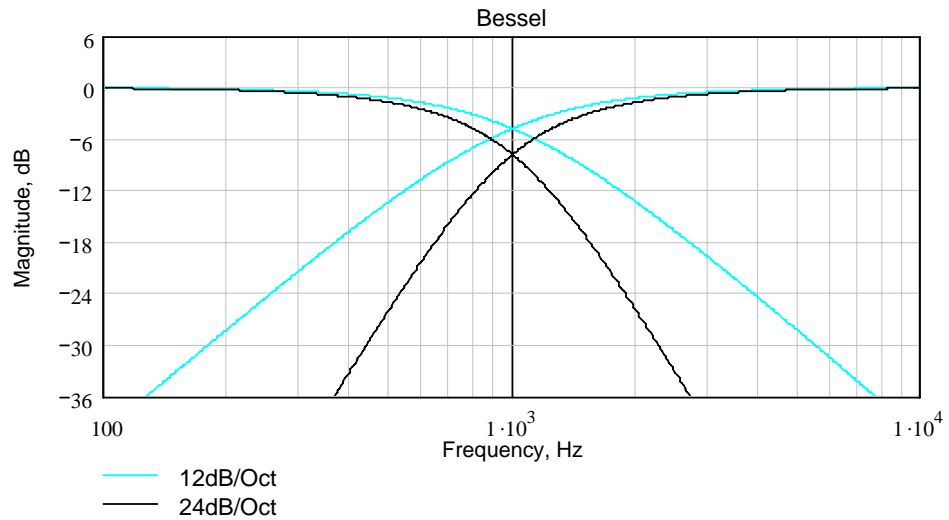

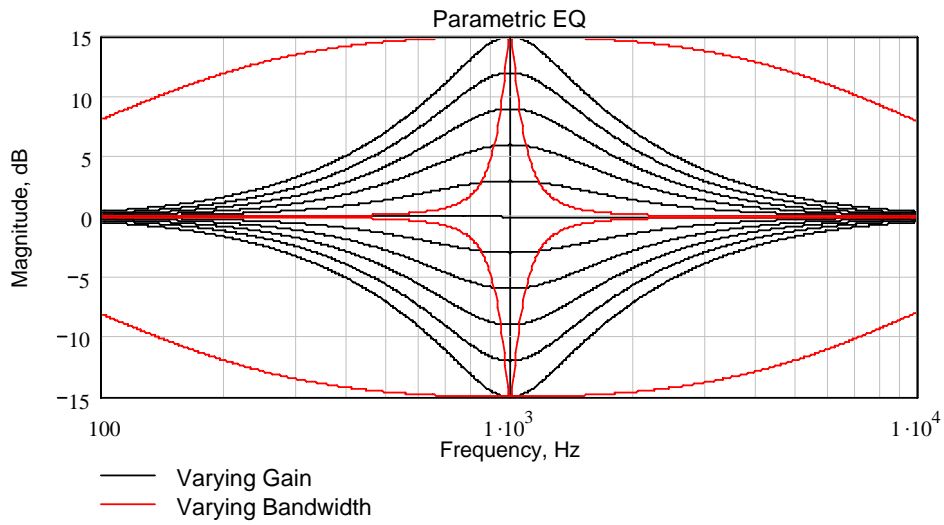
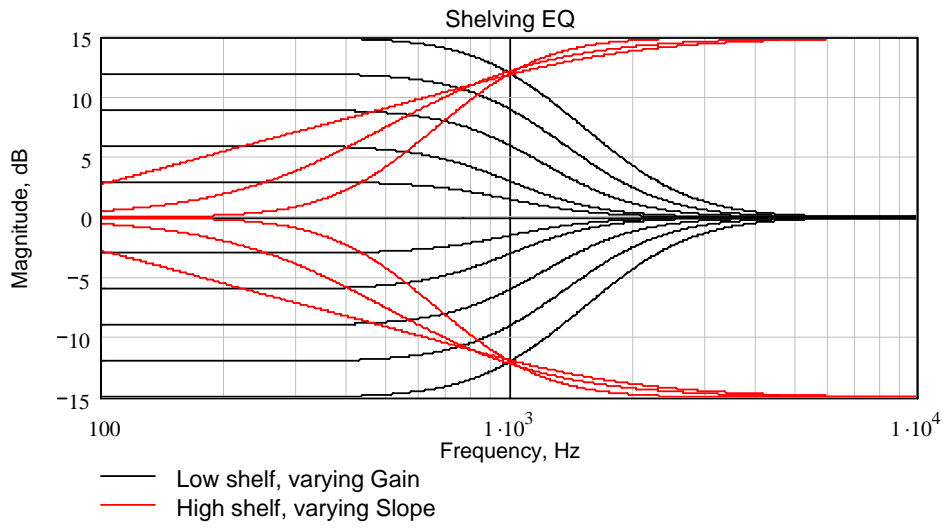

Technical Specifications

General

Inputs	Two, electronically balanced
Input impedance	> 10k ohms
Maximum input level	+20dBu
Outputs	Six (LMS-D26); Four (LMS-D24), electronically balanced
Output Impedance	< 100 ohms
Maximum output level	+20dBu into 600 ohm load
Sample rate	96kHz
Frequency Response	10Hz - 40kHz \pm 1dB (filters disabled) 10Hz - 20kHz \pm 0.25dB (filters disabled)
THD	< 0.01% (+10dBu 20Hz to 20kHz, 30kHz bandwidth)
Dynamic Range	>111dB (A weighted, 22kHz bandwidth) >108dB (unweighted, 22kHz bandwidth)
Serial Comms Data	38.4kbaud, format: 8 data, 1 stop, no parity

Processing

Gain	+20dB to -80dB and mute, 0.2dB steps
Output channel source	Input A, Input B and SUM
HP filter frequency	Off, 10Hz to 25.4kHz, 1/36 octave steps
LP filter frequency	10Hz to 25.4kHz and off, 1/36 octave steps
LP / HP filter type	12, 18 & 24dB / octave Bessel and Butterworth, 12, 24 and 48dB / octave Linkwitz-Riley and 4 th or 8 th order Hardman
Delay	Input 400ms, output 80ms
Limiter	High performance limiter, adjustable threshold in 0.2dB steps, automatic time constants
EQ frequency	10Hz - 25kHz, 1/36 octave steps
EQ gain	+15dB to -15dB, 0.2dB steps
EQ width	5.0 to 0.1 octaves bandwidth, 1/36 octave steps

Connectors

Audio inputs	3 pin female XLR
Audio outputs	3 pin male XLR
Serial comms	9 pin female 'D' type
Network comms	future option
Mains	3 pin IEC
Mains Power	Universal switch-mode PSU, 85 to 250v AC, 50/60Hz
Consumption	< 25 watts
Weight	2.7kg net (5.9 lbs)
Size	1.75"(1U) * 19" * 10" (44 * 482 * 254mm) excluding connectors

Due to continuing product improvement the above specifications are subject to change.

WARRANTY

This product is warranted against defects in components and workmanship only, for a period of one year from the date of shipment to the end user. During the warranty period, TURBOSOUND will, at its discretion, either repair or replace products which prove to be defective, provided that the product is returned, shipping prepaid, to an authorised TURBOSOUND service facility.

Defects caused by unauthorised modifications, misuse, negligence, act of God or accident, or any use of this product that is not in accordance with the instructions provided by TURBOSOUND, are not covered by this warranty.

This warranty is exclusive and no other warranty is expressed or implied. TURBOSOUND is not liable for consequential damages.

NOTES

Turbosound Ltd

Star Road, Partridge Green

West Sussex RH13 8RY England

Tel:+44 (0)1403 711447 Fax: +44 (0)1403 710155

web: www.turbosound.com